

GEAR REDUCER SERIES

齒輪減速機系列

MODEL : H

臥式減速機 Horizontal Type Reducer
RATIO : 1/3~1/30 (雙段 2-Stage)

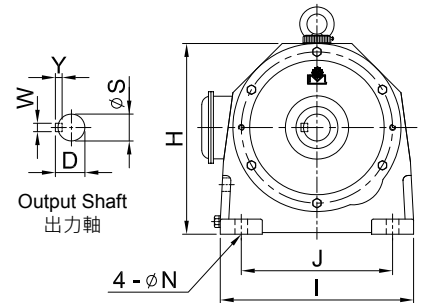
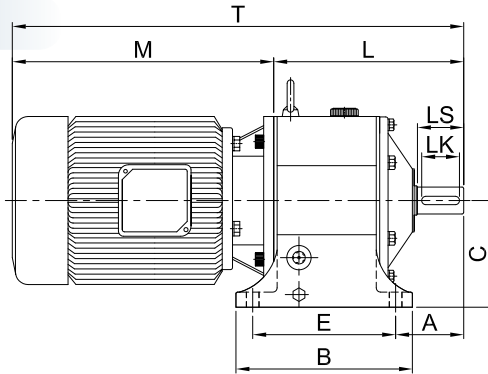

unit: mm

型號 Model	馬力 HP (4P)	減速比 Ratio	M	L	T	H	C	A	腳座 Foot Stock					出力軸 Output Shaft				重量 Weight (kg)	油量 Oil (ℓ)
									E	J	B	I	N	D	LS	S	WxYxLK		
201	1/4	3~30	225	165	390	170	90	54	125	140	155	180	10	21	38	19	5x5x30	8	0.5
202	1/2	3~10	248	171	419	170	90	60	125	140	155	180	10	27	45	24	7x7x35	8	0.5
203	1/4	31~50	225	178	405	190	110	62	135	145	170	190	13	27	45	24	7x7x35	10.5	0.7
	1/2	11~30	248		426														
205	1/2	31~50	248	231	479	227	127	77	170	180	210	230	15	31	50	28	7x7x40	18.5	1
	1	3~30	242	222	464														
206	2	3~10	322	226	548	227	127	81	170	180	210	230	15	35	55	32	10x8x45	18.5	1
207	1	31~40	242	254	496	253	145	80	205	195	240	260	15	35	55	32	10x8x45	25.5	1.4
	2	11~30	322		576														
208	3	3~10	315	259	574	265	145	87	205	195	240	260	15	41	60	38	10x8x50	28	1.4
209	2	31~40	322	290	612	289	164	88	215	215	265	295	19	41	60	38	10x8x50	34	2
	3	11~30	315		594														
209S	2	31~40	322	279	601	286	164	86	215	215	265	280	19	41	60	38	10x8x50	31	2
	3	15~30	315		268														
210	5	3~10	371	283	654	289	164	92	215	215	265	295	19	45	65	42	12x8x55	36	2
210S			273	644	286														
211	3	31~40	315	325	640	332	192	109	250	270	295	345	19	51	75	48	12x8x65	56	3
	5	11~30	371		696														
211S	5	11~30	298	669	289	164	105	215	215	265	295	19	51	75	48	12x8x65	46	2.5	
212	7 1/2	3~10	374	325	669	332	192	109	250	270	295	345	19	51	75	48	12x8x65	56	3
	10	3~10	412		737														
213	7 1/2	11~30	374	385	759	385	210	125	310	310	370	400	22	60	80	56	15x10x70	93	6.5
	15	3~10	498		883														
213S	7 1/2	11~30	374	382	756	377	210	125	310	310	370	390	22	60	80	56	15x10x70	86	6.5
	15	3~10	498		394														
214	10	11~30	412	390	802	385	210	130	310	310	370	400	22	66	85	62	15x10x75	97	6.5
214S			387	799	377														
215	15	11~30	498	471	970	445	245	157	360	360	430	450	25	76.5	100	72	20x12x90	149	10
	20	3~10	542		1,013														
216	20	11~30	542	471	1,013	445	245	157	360	360	430	450	25	80.5	100	76	20x12x90	151	10
	25	5~10	562		1,033														
217	25	11~30	562	508	1,070	505	280	172	380	420	460	530	25	84.5	110	80	20x12x100	205	15
	30	4~30	600		1,108														
218	40	11~30	600	608	1,208	565	310	196	480	480	570	600	28	106.5	130	100	24x16x120	335	24
	50	5~10	660		1,268														
219	50	11~30	660	676	1,336	670	380	214	540	500	635	670	28	124	150	115	32x20x140	485	32
	60	5~10	676		1,352														
220	75	11~30	676	792	1,468	782	425	272	600	680	700	830	38	139	180	130	35x22x170	760	45

1. 表中 S 表示新尺寸。"S" means new dimension.

2. H213(含) 以上有雙油鏡雙排油孔。The model above H213 have dual oil gauges & drain plugs.

3. 重量不含馬達及潤滑油。The weight does not include motor and lubricant.

MODEL : H

臥式減速機 Horizontal Type Reducer
RATIO : 1/31~1/200 (三段 3-Stage)

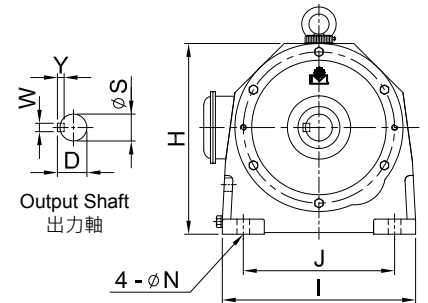
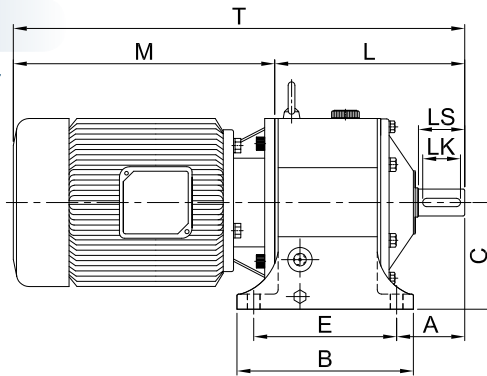

unit: mm

型號 Model	馬力 HP (4P)	減速比 Ratio	M	L	T	H	C	A	腳座 Foot Stock					出力軸 Output Shaft				重量 Weight (kg)	油量 Oil (ℓ)
									E	J	B	I	N	D	LS	S	WxYxLK		
304	1/4	51~120	225	194	419	190	110	68	135	145	170	190	13	31	50	28	7x7x40	12	0.7
	1/4	121~200	225	236	461	227	127	81	170	180	210	230	15	35	55	32	10x8x45	20.5	1
306	1/2	51~120	248	268	484														
	308	1/2	121~200	248	268	516	253	145	85	205	195	240	260	15	41	60	38	10x8x50	28
1		40~120	242	259	501														
310	2	31~40	322	306	581	289	164	92	215	215	265	295	19	45	65	42	12x8x55	39	2
	2	121~200	242	297	628														
310S	1	121~200	242	297	538	286	164	92	215	215	265	295	19	45	65	42	12x8x55	37	2
	2	60~120	322	297	618														
312	2	121~200	322	348	670	332	192	109	250	270	295	345	19	51	75	48	12x8x65	61	3
	3	41~120	315	337	652														
312S	5	31~60	371	337	708	289	164	105	215	215	265	295	19	51	75	48	12x8x65	53	2.5
	1	121~200	242	323	565														
314	2	51~120	322	323	645	385	210	130	310	310	370	400	22	66	85	62	15x10x75	105	6.5
	3	121~200	315	413	728														
314S	5	60~120	371	410	784	377	210	130	310	310	370	390	22	66	85	62	15x10x75	103	6.5
	3	121~200	315	410	725														
315	7 1/2	31~50	374	402	776	445	245	157	360	360	430	450	25	76.5	100	72	20x12x90	169	10
	5	121~200	371	487	858														
316	10	60~120	412	492	904	445	245	157	360	360	430	450	25	80.5	100	76	20x12x90	169	10
	15	31~50	498	492	990														
317	7 1/2	121~200	374	539	913	505	280	172	380	420	460	530	25	84.5	110	80	20x12x100	220	15
	15	40~120	498	523	1,021														
318	20	40~50	542	523	1,065	565	310	196	480	480	570	600	28	106.5	130	100	24x16x120	366	24
	10	150~200	412	628	1,040														
319	15	121~200	498	628	1,126	670	380	214	540	500	635	670	28	124	150	115	32x20x140	529	32
	20	60~120	542	628	1,170														
319	25	60	562	628	1,190	670	380	214	540	500	635	670	28	124	150	115	32x20x140	529	32
	30	40~50	562	628	1,190														
319	20	121~200	542	696	1,238	670	380	214	540	500	635	670	28	124	150	115	32x20x140	529	32
	25	70~90	565	696	1,261														
319	40	40~60	603	696	1,299	670	380	214	540	500	635	670	28	124	150	115	32x20x140	529	32
	40	40~60	603	696	1,299														

- 表中 S 表示新尺寸。"S" means new dimension.
- H314(含) 以上有雙油鏡雙排油孔。The model above H314 have dual oil gauges & drain plugs.
- 重量不含馬達及潤滑油。The weight does not include motor and lubricant.